

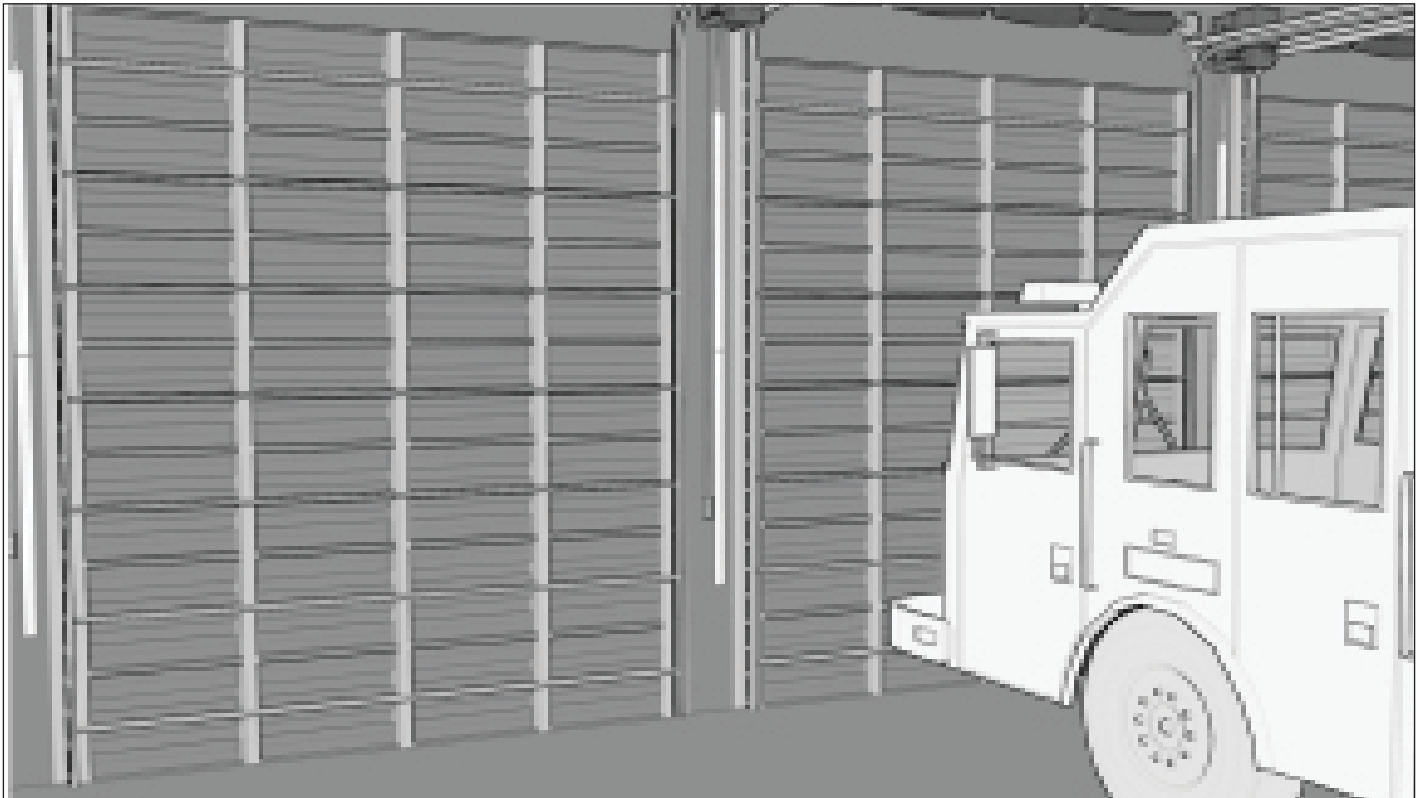

LED SAFETY LIGHT SYSTEMS



## **COMMERCIAL DOOR LIGHT KIT**

CDLK5 / CDLK10 / CDLK15 / CDLK20

## **INSTALLATION MANUAL**

[www.BrinkAlert.com](http://www.BrinkAlert.com)



## **IMPORTANT SAFETY INFORMATION**

**For safe installation and trouble-free operation, YOU MUST:**

- Carefully read this instruction manual before beginning.
- Always use appropriate PPE during installation including safety glasses, gloves and hearing protection as needed.
- Follow each installation step exactly as shown.
- Observe all local, state, and national electrical codes.
- Pay close attention to all danger, warning, and caution notices given in this manual.
- Always use the parts supplied by the manufacturer or other prescribed parts unless directed otherwise.

**NOTE:** Use of non-prescribed parts can cause serious accidents such as the unit to fall, electric shock, or fire.

**USE CAUTION WHEN WIRING: ELECTRICAL SHOCK CAN CAUSE SEVERE PERSONAL INJURY OR DEATH. ONLY QUALIFIED & EXPERIENCED INSTALLERS SHOULD ATTEMPT TO WIRE THIS SYSTEM.**

- Do not supply power to the unit until all wiring and connections are completed or reconnected and checked.
- Highly dangerous electrical voltages and moving parts are used in the operator. Carefully refer to the wiring diagram and these instructions when performing any wiring.
- Ground the unit following local electrical codes.
- Connect all wiring tightly. Loose connections can become disconnected due to vibrations from heavy door equipment.
- Install as directed. BrinkAlert LED Safety Light Systems and LED Controllers are intended for use as described herein and by the product literature available for download at [www.BrinkAlert.com](http://www.BrinkAlert.com).
- Any misuse, alteration, or modification of BrinkAlert branded products beyond what is described in the available product literature will void all warranties.

## KIT COMPONENTS

- (1-4) LED Strip(s) (5-20ft) [**LED##**]
- (1-4) 20-30ft LED Harness Cable(s) [**HARNESS##-G**]  
Additional lengths available from 10-100ft
- (1-4) LED Retainer Track(s)
- (1) CDLK LED Controller [**CONTROL-CDLK**]
- (1) 110V to 24VDC Power Supply [**PS24VIN**]
- (1) 10ft Signal Cable (4-wire 22AWG)
- (1) Installation Manual

**CDLK LED  
CONTROLLER**

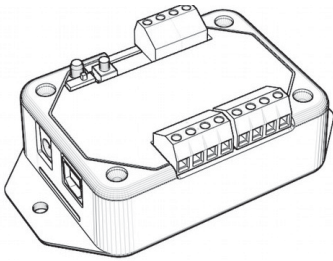

**SIGNAL CABLE**

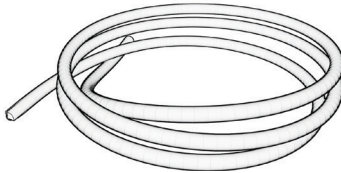

**LED STRIP**

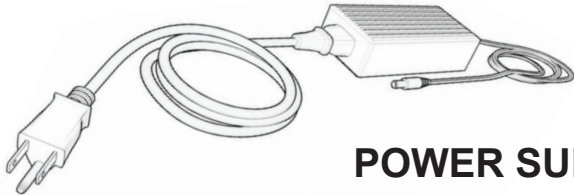
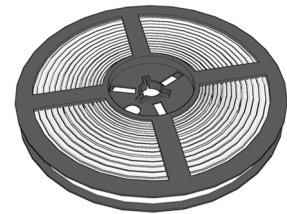

**POWER SUPPLY**



**LED HARNESS CABLE**

*You should also have received (1) to (4) pieces of 5ft LED retainer track per kit ordered, in one or more of the following track styles:*

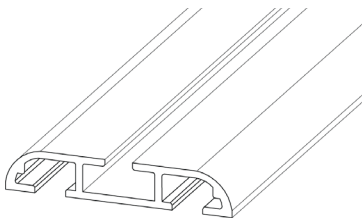

**TRACKDUAL5**

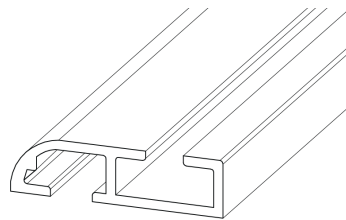

**TRACKSNG5**

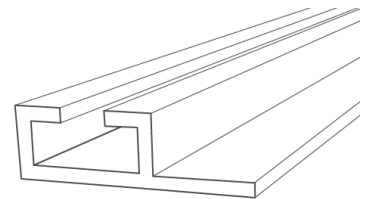

**TRACKSNG5-CLASSIC**

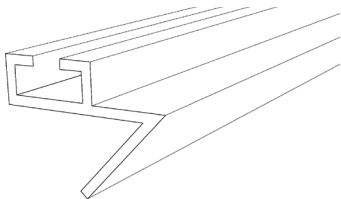

**TRACK455**

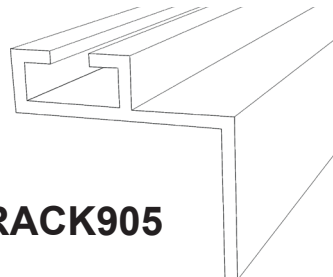

**TRACK905**

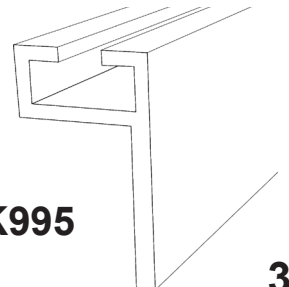

**TRACK995**

## RECOMMENDED TOOLS & SUPPLIES (not included)

- Ladder or Lift
- Wire Stripper
- Multimeter
- Screwdrivers (various)
- Utility Knife
- Doubled-sided foam tape or velcro
- Cleaner or Degreaser
- Clean Rags
- Dielectric Grease
- Zip Ties
- Marker

### For Liftmaster or Limit Switch Installaion include these items:

- Terminal Crimper
- Red Crimp Terminals - Spade

### For OHD - Brand Installations, include these items:

- 1/4" Socket
- Socket Wrench
- Long Wrench Extension
- OHD-brand Auxillary Expansion Module (available at OHDParts.com)

### Some installations will require an AC Signal Converter

[ACSIGNALCONVERT4]

OR

[ACSIGNALCONVERT7]

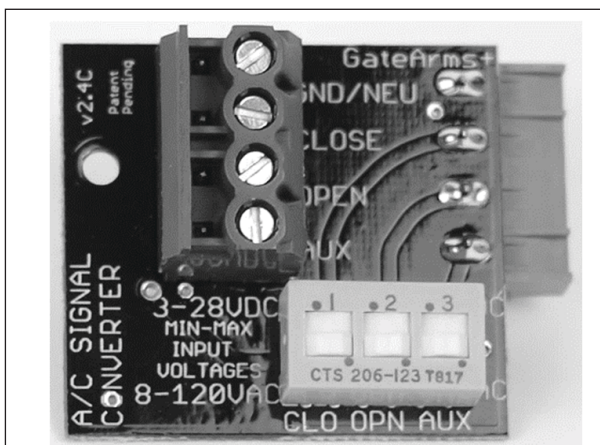

\*LED Controller = Mode 3

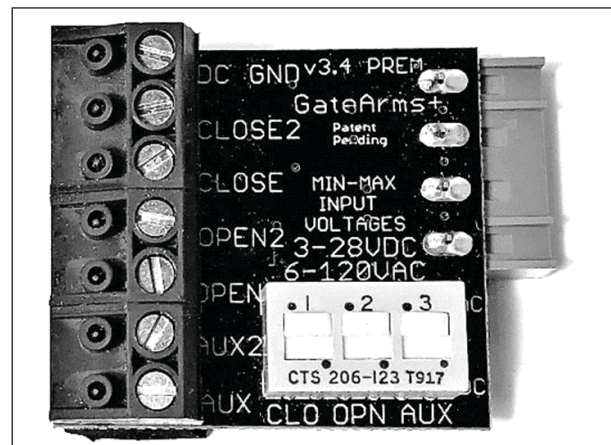

\*LED Controller = Mode 1 or 2

# **INSTALLATION OVERVIEW**

## **1. INSTALL LED RETAINER TRACK**

The installation method of the LED retainer track depends on whether you are installing the standard LED retainer (rolling steel door) or the 90° retainer (sectional door).

### **a. Standard LED Retainer Installation (Rolling Steel Door)**

The standard LED retainer is installed directly on the wall using screws or 3 strips of double-sided foam tape per track.

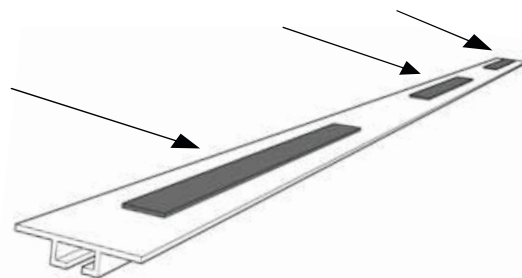

### **b. 90° LED Retainer Installation (Sectional Door)**

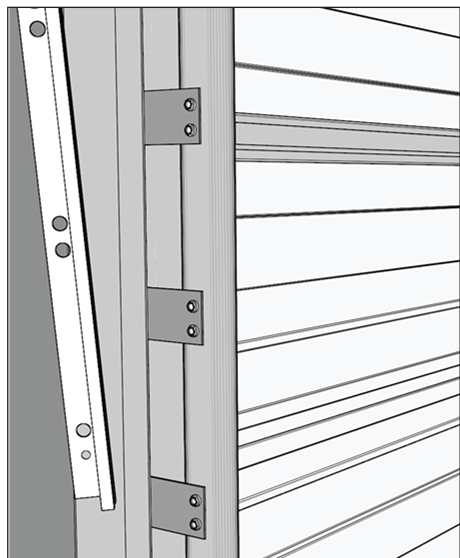

The 90° LED retainer is typically installed on a sectional door's guide rails. Mark and drill out holes in the LED retainer's flange where the guide rail bolts are located. Attach LED retainer track to the door's guide rails using the existing bolts and nuts.

## **2. INSTALL LED STRIP**

a. Insert the cable end of LED strip into bottom end of lower retainer. Pull cable straight up along the length of track.

b. When fully-installed, crimp both ends of retainer track with pliers to ensure LED strip doesn't slide down in the track due to time or vibrations.

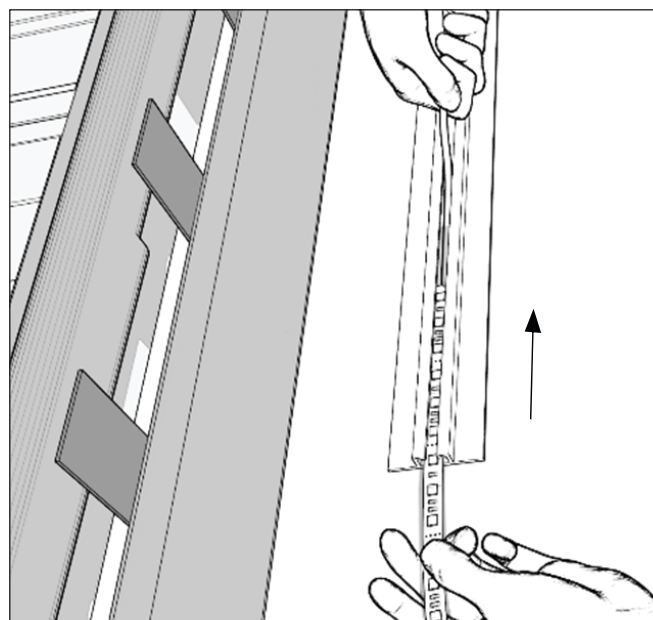

*Pull cable through retainer track from bottom upwards*

### 3. CONNECT LED STRIP TO LED HARNESS CABLE

Plug one end of the connector into the other using the arrow alignment notch. Tighten nut onto the connector.

There is dielectric grease inside the connector that ensures longevity of your connection points and creates a proper seal.

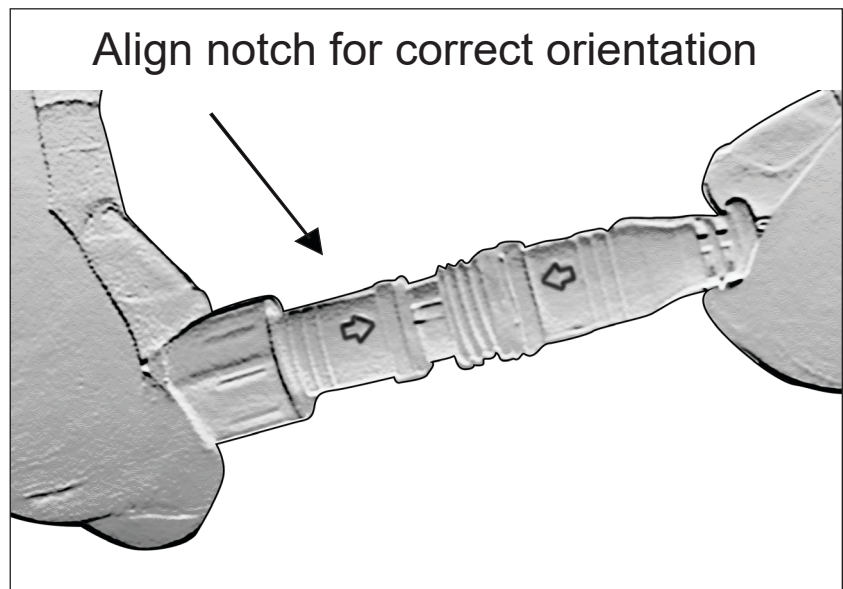

### 4. ROUTE LED HARNESS CABLE TO DOOR OPERATOR

Route the LED Harness Cable(s) from the LED strip(s) to the top of the door operator (or wherever you will mount the LED Controller), ensuring clean cabling.

### 5. USING A/C or D/C SIGNALS?

Determine if your operator control board uses A/C or D/C for informational signals (ex: at limit switches).

A/C signals may damage the LED Controller.

We manufacture an A/C Signal Converter (optional accessory) that allows for A/C signal use (maximum 120VAC). If you have a mixed scenario where some signal wires use A/C and others use D/C, please contact BrinkAlert Tech Support at

786-339-9840 and we will guide you through the programming. If all signals are D/C, **DO NOT** use the A/C Signal Converter board.

**NOTE:** An easy guide is to check the safety eye voltage for A/C. If none exist, it is a D/C system.

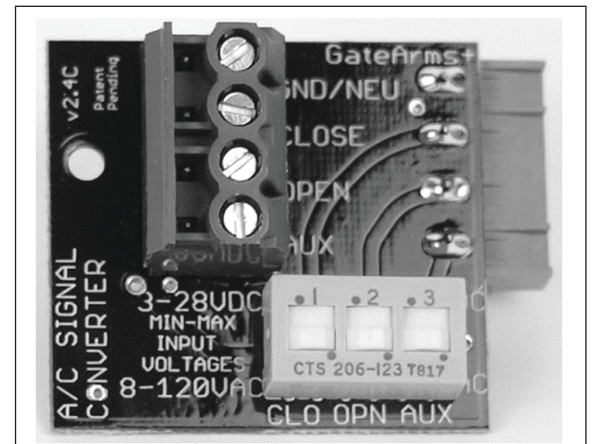

## 6. TURN OFF ALL POWER TO THE OVERHEAD DOOR EQUIPMENT



**WARNING:** Serious injury could occur if power is not disconnected prior to installation.

## CONNECT LED CONTROLLER TO OPERATOR

### 7. STAGE THE LED CONTROLLER

- a. Confirm the LED Controller's power switch is turned OFF.
- b. Use velcro or double-sided foam tape to secure the LED Controller & power supply to the door operator's control box. Before applying adhesive to any surfaces, clean the contact areas throughly with a degreaser, then dry.  
**NOTE:** NEMA Box with LED Controller and power supply pre-installed.
- c. Ensure that heat and humidity will not affect your attachment method.
- d. Connect the power supply's 24V plug to the LED Controller. Zip tie the 24V plug to the LED Controller's loop.

### 8. CONNECT THE LED STRIP TO THE LED CONTROLLER

Connect the LED strip's Harness Cable to the LED Controller's "MAIN LED STRIP" header as shown. Match the colors on the wire to the color described on the cover corresponding to each header port. Screw headers and wires should always face outwards from center.

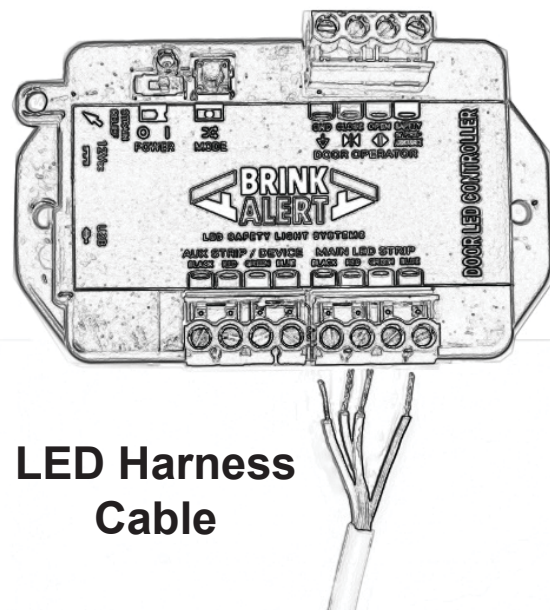

LED Harness Cable

## 9. CONNECT SIGNAL CABLE TO LED CONTROLLER

Connect one end of the 4-wire Signal Cable to the LED Controller's Signal Header as follows:

- Connect the Black Wire to the Controller's GND port.
- Connect the Red Wire to the Controller's CLOSE port.
- Connect the Green Wire to the Controller's OPEN port.
- Connect the 4th Wire (Yellow, White or Blue) to the Controller's SAFETY Signal port.

## 10. PASS CABLE THRU HOLE INTO OPERATOR HOUSING

Pass the Signal Cable into the door operator's housing through an existing punch-out or by drilling a hole.

Consider using a cable strain relief gland in the hole.

**NOTE:** Avoid sharing a hole with the high voltage lines.

## 11. CONNECT SIGNAL CABLE TO OPERATOR

Connect the Signal Cable to the door operator's control board. Follow the wiring guide specific to the operator make and model. See the Wiring Schematic insert for most common operators.

If you do not find your operator in the Wiring Schematic insert, please call BrinkAlert Tech Support at 786-339-9840 for further assistance.

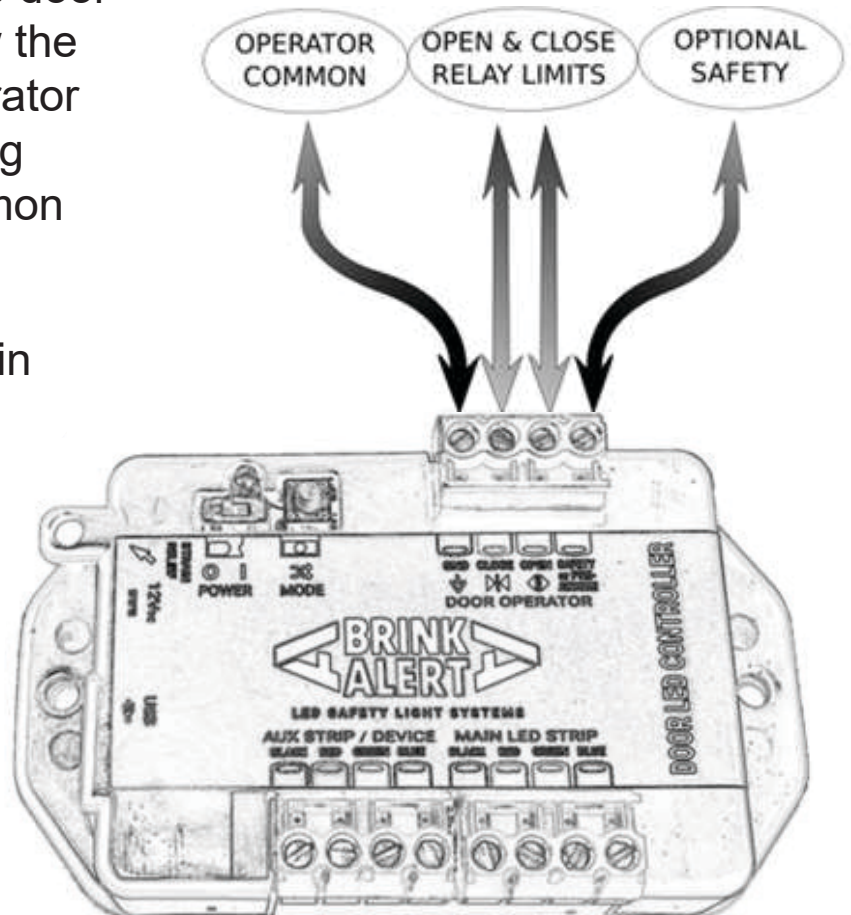



## **12. POWER-UP & TEST THE CONFIGURATION**

- a. Plug the 24V power supply into a live 110VAC outlet.  
Note: Power supply can accept 100-240VAC and can be hard-wired into the operator's load power.
- b. Ensure 24VDC cable is connected to the LED Controller.
- c. Power-up the LED Controller using its power switch.
- d. LEDs should turn on immediately. If not, turn power off and check all connections.

## **13. TEST THE LED CONFIGURATION**

Open and close the garage door several times.

- LEDs should be solid red when door is fully closed.
- LEDs should flash red whenever door is in motion.
- LEDs should be solid green when the door is fully open.
- If a safety device is installed and it is triggered while door is in motion, the LEDs should be flashing white. There is a 20 second delay before flashing white if the LEDs were green.
- If the safety device is ignored when door is fully-closed, the LED will flash blue when the safety device is disconnected or offline.

If there are any problems with the LED behaviour during these events, turn off the door operator and review your wiring. You can refer to the troubleshooting section (Appendix D) of this manual for common issues.

---

***Still need help? Call our Tech Support line at (786)339-9840.***

There are many subtle configuration settings that can be tweaked to get your project working. We are eager to help you ensure that EVERY PROJECT IS A SUCCESS!

# CONGRATULATIONS!

You have completed the installation.

Run into an issue? No worries, we have you covered.

**Appendix A** will help you install the Configuration Tool program. See LED Controller Programming insert after software installation.

**Appendix B** will help you with the Safety Device Condition, Door Status and LED Strip Color.

**Appendix C** will help you power and monitor external devices needed.

**Appendix D** will help guide you through some common issues.

**Wiring Schematic Insert** will help you wire to the most common door operators. Contact Tech Support if your operator is not listed.

**LED Controller Programming Insert** will help guide you with programming the LED Controller's optional features.

# APPENDIX A: INSTALL THE CONFIGURATION TOOL

## INSTALL PROGRAM

1. Visit [www.BrinkAlert.com/downloads](http://www.BrinkAlert.com/downloads) and click on the LED Controller Configuration Software to download.
2. You may need to stop any antivirus programs that are running.
3. Open (run) downloaded file with Administrative rights to install it.

## CONNECT CONTROLLER TO PC

1. Detach power from LED Controller.
2. Use a Type-B (printer) USB cable (not included) to connect the LED Controller to the PC.
3. The PC should immediately recognize that the device was connected, although it will not install any supporting driver software.
4. Use the Configuration Tool to program the LED Controller.
5. Detach the USB Cable from the LED Controller.
6. Test LED Controller on your door.

**NOTE:** If device is NOT RECOGNIZED, you will need to manually connect the driver file to the device using the following steps:

1. Open Device Manager in Windows
  - a. Right-click “Computer”, then choose “Manage”
  - b. Or, click “Start Button”, then “Administrative Tools”, then “Computer Management”, then “Device Manager”
2. Find “LED Driver” with an alert mark on it, probably in “Unknown Devices” group
3. Right-click that item, then choose “Update Driver Software”
4. Click “Browse...click “Browse” again if necessary, to search your computer C: drive
5. Open “Program Files (x86)”
6. Find folder “BrinkAlert.com”, then “Configurator”, then “Driver”  
Click the “Driver” folder, then click “OK” button
7. Click the “Next” button and “Close”.

## **APPENDIX B: MONITOR SAFETY EYE OR SAFETY DEVICE**

If the door has a safety device such as an electric eye or laser presence detector installed, its output can be connected to the “Safety or Pre-Announce” Signal port of the LED Controller so that the LED strip can flash white when safety is tripped (optional). If not needed, leave this port disconnected.

<b>Safety Device Condition</b>	<b>Door Status</b>	<b>LED Strip Color</b>
All Clear	Fully Closed	Red
All Clear	Fully Opened	Green
Doorway Blocked	Fully Closed	Red (signal ignored)
Doorway Blocked	Moving	Flashing White
Doorway Blocked	Fully Opened	Green for 20 sec then Flashing White
Device Fault	Any	Flashing Blue

If the safety device is UL325 compliant, it will be detected when the LED Controller powers up. If no device is detected on power-up, the “Safety or Pre-Announce” Signal port will be ignored unless programmed for a special function.

## **APPENDIX C: POWER & MONITOR EXTERNAL DEVICES**

The LED Controller’s 2nd LED header (called “AUX STRIP / DEVICE”) can serve as a power supply for external devices that use 24VDC and less than 2 Amp. We offer a variety of special firmware options to enable various scenarios.

Contact our Tech Support Team for help!

### **Monitor Non-UL325 Device (Current-Sense Mode)**

If a safety device (like a BEA Falcon) can operate at 24VDC, it is possible to continuously monitor the device’s existence and functionality by using the LED Controller as its power source. If the LED Controller senses an unusual drop in current consumption of the safety device, the LED strip will flash blue rapidly to indicate the device is malfunctioning. Simply attach the safety device’s power wire (positive) to the “AUX STRIP / BLACK” terminal and its ground wire (negative) to the “AUX STRIP / BLUE” terminal.

**NOTE:** You must also program the LED Controller for this scenario.

<b>AUX STRIP - Blue Port Current Draw</b>	<b>LED Strip Color</b>	<b>Door Status</b>
Higher than ~10mA	Not Affected	Normal Operation
Lower than ~10mA	Rapid Flash Blue	Safety Eye Offline

### **Powering and Triggering Horns and Alarms**

The LED Controller can power audio alarms at any stage, including during pre-announce and descent.

### **Powering High Voltage Equipment**

Installers can use the LED Controller’s “AUX STRIP” port to trigger external relays which control high voltage devices.

## **APPENDIX D: TROUBLESHOOTING**

*Lights do not turn on*

### **Possible Issue: Power Supply Problems**

- Check LED Controller. Is its amber LED on?
- Is the 110V power adapter on? Check 110V power wiring at the operator's power source. Trace wire from LED Controller.
- Check Press-on Headers. Are the wires well-secured? Are they pressed in vertically all the way? Screws facing outwards? Match wire colors with the words on the LED Controller's cover.
- Ensure the external connector mating the LED Harness Cable to the LED Strip is fully connected. Check pins inside the connector.

*Lights do not change colors or keep flashing red*

### **Possible Issue: Signal Wire Problems**

- Signal wiring is disconnected.
- Use a multimeter to determine what type of signals exist for fully-open and fully-closed. Use the Wiring Guide insert to determine which profile you should be using.
- Check if the LED Controller is properly grounded to the same Common in use by the Operator.
- Potential programming issue with LED Controller.

If an A/C system, ensure Common is attached to the Operator's chassis and is truly grounded.

**REMINDER:** If installing on an A/C system, the LED Controller must use an A/C Signal Converter Board.



LED SAFETY LIGHT SYSTEMS

TECH SUPPORT HOURS  
MONDAY-FRIDAY  
9:00AM - 5:00PM EST

-----

(786) 339-9840  
[www.BrinkAlert.com](http://www.BrinkAlert.com)  
[support@brinkalert.com](mailto:support@brinkalert.com)

LED Controller Patent # 11089662

© 2024 BrinkAlert  
All Rights Reserved

***Manual Rev# 2024-03v1.0***

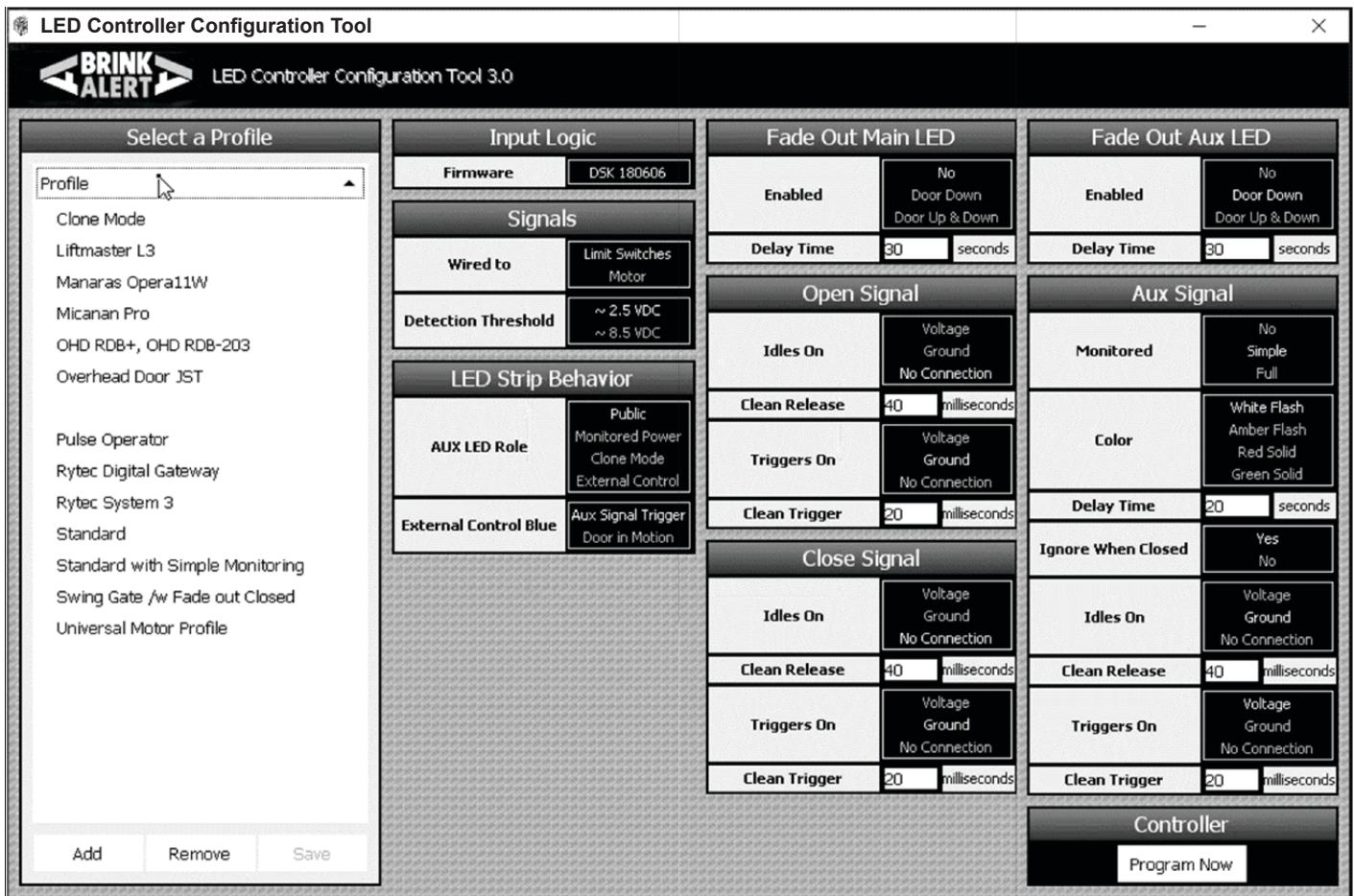

\* Visit [www.BrinkAlert.com/downloads](http://www.BrinkAlert.com/downloads) to download the software.

### Signals

**Wired to:** If using a manual door operation, select “Limit Switches”. If wiring to a door operator, select “Motor”.

**Detection Threshold (2.5V / 8.5V):** Trigger is fired when voltage crosses this threshold. Default is 2.5V.

### “Signals – Noise Cleaning”

The LED Controller is extremely sensitive to voltage changes, so it only will consider a voltage change significant if it persists for longer than the noise cleaning milliseconds. Shorter signals are ignored.

### “Idles On” (Voltage / Ground / No Connection)

Defines the input’s default state when there is no activity at the door.  
**[VOLTAGE]** The signal input will idle with voltage on the pin.  
**[GROUND]** The signal input will idle with ground on the pin.  
**[NO CONNECTION]** The signal input will idle on a disconnected circuit.

### “Triggers On” (Voltage / Ground / No Connection)

Defines what causes a signal to fire.  
**[VOLTAGE]** The signal input will trigger on voltage higher than the “Signals-detection threshold” voltage in configuration tool.  
**[GROUND]** The signal input will trigger on ground.  
**[NO CONNECTION]** The signal input will trigger when the grounded (or powered) circuit loses continuity and then “floats”.

### Fade Out Main LED / Fade Out Aux LED

**Enabled:** LEDs can be forced to fade-off after timed duration.  
**[No]** No fadeout.  
**[Door Down]** Fade-off when door reaches closed limit (after timed delay).  
**[Door Up & Down]** When door reaches either limit.  
**Delay Time:** Delay time before fade-off.

### LED Strip Behavior

**AUX LED Role:** Controls role of second LED header (AUX STRIP).  
**[Public]** AUX STRIP can fade-off after timed duration.  
**[Monitored Power]** AUX STRIP header can power safety eye and monitor its viability.  
**[Clone Mode]** Sets both LED headers to be identical.  
**[External Control]** Sets AUX STRIP header as a 24VDC power supply (Green is triggered on fully-open, Red is triggered on fully-closed, Blue is triggered on “moving”).  
**External Control Blue:** AUX LED Blue pin can be programmed to trigger.  
**[AUX Signal Trigger]** AUX Blue pin triggered in 2 scenarios when AUX Signal received.  
**[Door in Motion]** AUX Blue pin triggered when door is in-motion.

### AUX Signal

**Monitored:** AUX Signal pin can connect to safety eye signal to monitor activity.  
**[No]** No monitoring.  
**[Simple]** Non UL-325 signal.  
**[Full]** UL-325 compliant signal.  
**Color:** Color to show if safety eye is triggered.  
**[White Flash, Amber Flash, Red Solid or Green Solid]**  
**Delay Time:** Delay before colors react to safety eye trigger.  
**Ignore When Closed:** Ignore safety eye triggers if door is at fully-closed limit.



## PROGRAM THE LED CONTROLLER MANUALLY

LED Controllers are shipped from our factory pre-programmed and ready to use. You can program most features using the LED Controller Configuration Tool on the PC or using the Mode button and 1 or 2 jumper wires. Contact BrinkAlert Tech Support for assistance with any programming needs.

**NOTE:** Programming with a jumper is easy when no computer is available. If you need to program several controllers at once you should use the PC Configuration Tool. This program is also better for setting timers precisely.

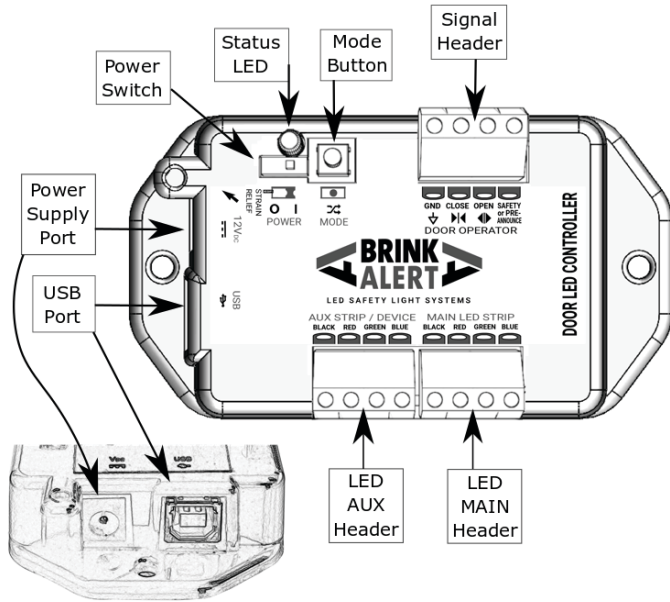

## Using MODE Button

1. Turn on LED Controller
2. Hold/Release Mode button for 3 sec. to rotate through 3 scenarios.
3. To remove special Programming, hold Mode button down for approximately 3 seconds (with no jumpers) until fading effect of status LED reverts to solid.

Mode	Primary Configuration	Status LED	AUX LED Strip
1	Standard Operator L4/L5	Steady Light	Fades Off (30 sec delay)
2	Standard Operator Clone Mode	Slow Flashing	Clone Mode
3	A/C Signal Converter w/ non-UL325 safety device	Fast Flashing	Clone Mode

## Single-Action Programming

1. Remove all press-on headers temporarily.
2. Turn off LED Controller using power switch.
3. Connect jumper wire between 2 pins as described above.
4. While holding "Mode" button down, turn on power switch. Status LED will flash for 2 seconds. Release button. Feature is now set.
5. Turn off LED Controller. Remove jumper wire, reattach press-on headers. Turn on LED Controller.

## Multi-Action Programming

- Use for setting dimming level, duration of timers, and other features.
1. Follow single-action programming completely.
  2. Either tap or hold-down the Mode button, depending on need.
    - a. For setting the dimming level: Press and release "Mode" button quickly. Each tap dims by 1 level (16 levels).
    - b. For setting time: Hold the "Mode" button for the duration you desire. Time is set when you release the button.
  4. Turn LED Controller off, then back on again using its power switch.

## Single-Action Programming

Feature	Jumper Connections	Description
Enable Clone mode	Aux Red → Close	Enables clone mode (Main & AUX LEDs are identical on both sides). <u>Note:</u> Mode 2 is also Clone Mode.
Enable Triggered Pre-Announce	Main Red → Open	Amber flashing prior to door descent (requires door operator's pre-announce or trigger to be wired to LED Controller's AUX Signal pin).
Enable A/C Signal Converter Basic	Main Blue → Open	Configures LED Controller to use A/C Signal Converter v4 (basic).
Power Source Mode	Aux Red → Safety	Used to power external devices, typically a 24V safety sensor. The Aux Blue port detects loss of current and LEDs flash blue if the safety sensor malfunctions.
Safety - Half-Monitored	Main Red → Safety	For certain safety eyes using heartbeat > 10 Hz.
Safety - Non-Monitored	Main Green → Safety	Supports simple on/off safety signals (non-UL325).

## Multi-Action Programming

(All Multi-Actions are simpler to set with the PC Program)

Feature	Jumper Connections	Description
Configure Safety Delay	Main Red & Main Blue → Close	Length of time the safety beam must be blocked when the door is opened before the safety color appears.
Enable Timed Pre-Announce	Main Blue → Safety	Length of time the fully-open lights remain Green before beginning to flash Amber, indicating door is about to close. Default is 8 seconds.
Configure Shut-off <u>Inside</u> LED	Main Blue → Open Main Green → Close	Set time before Inside LED shuts OFF (door fully-closed).
Configure Shut-off <u>Outside</u> LED	Main Blue → Open Main Red → Close	Set time before Outside LED shuts OFF (door fully-closed). Default is 30 seconds.
Configure Brightness for Main LEDs	Main Green → Close	Main LED strip will rotate through 16 levels of brightness on each button tap until set.
Configure Brightness for Aux LEDs	Main Blue → Close	Main LED strip will rotate through 16 levels of brightness on each button tap until set.

# Liftmaster L3 CDO Wiring

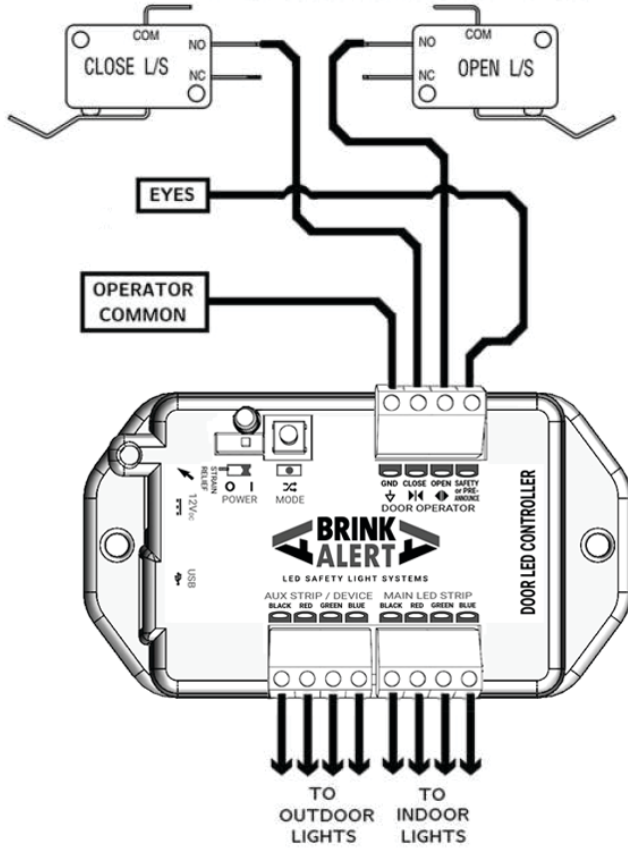

**PROGRAM THE LED CONTROLLER:**  
 Hold Mode button to select Mode 1 or 2  
 Mode 1: AUX LED fades off (30 seconds).  
 Mode 2: AUX LED same as MAIN

**IF USING UNMONITORED SAFETY EYES, PROGRAM THE LED CONTROLLER:**

1. Turn off LED Controller using power switch.
2. Remove all press-on headers temporarily.
3. Connect jumper wire between Main Green and Safety
4. While holding the "Mode" button down, turn on power switch. Status LED will flash for 2 seconds. Release button. Feature is now set.
5. Turn off LED Controller. Remove jumper wire, reattach press-on heads. Turn on controller.

# Liftmaster L4 / L5 CDO Wiring

**PROGRAM THE LED CONTROLLER**  
 Mode 1: AUX LED fades off  
 (Default is 30 seconds)  
 Mode 2: AUX LED same as MAIN  
 (Clone mode)

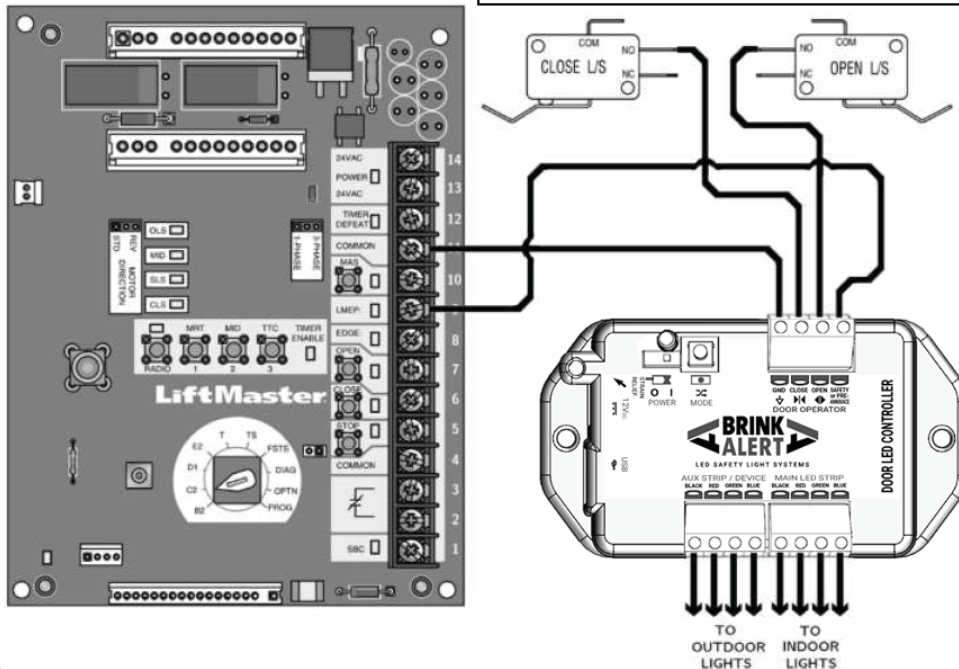

# OHD RSX CDO Wiring

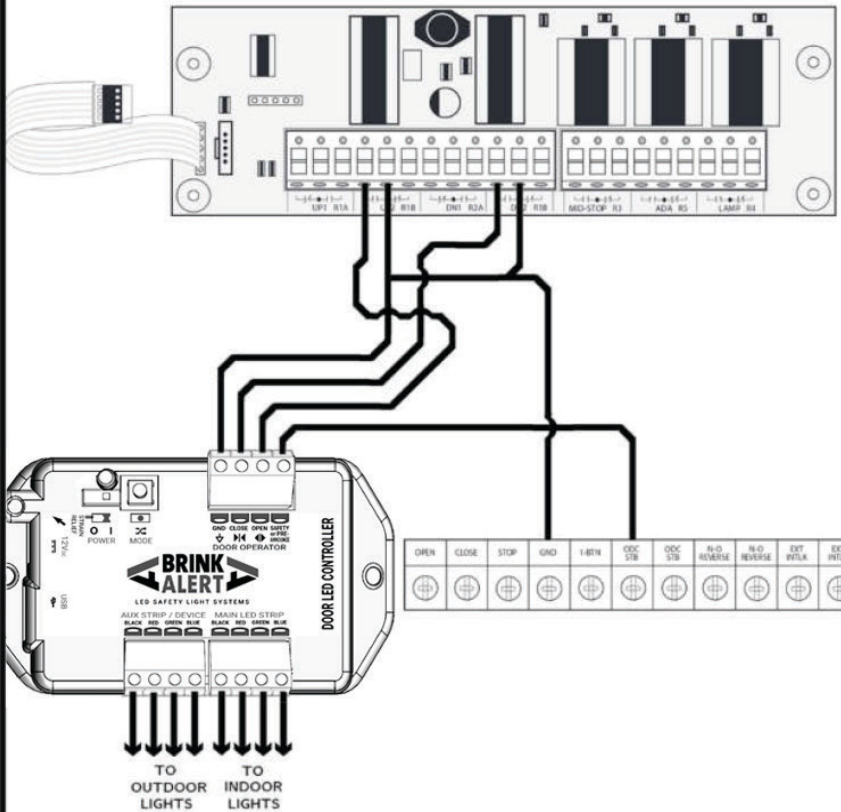

This OHD model requires use of the OHD-brand Auxiliary Output Expansion board.

PROGRAM the LED CONTROLLER (if connecting AUX to safety eyes):

1. Power Off the LED Controller
2. Remove LED headers and Signal header
3. Attach jumper wire between LED Main Red and Signal Aux.
4. Hold the Mode button and, while holding, set power switch to ON. Let go of Mode button.
5. Power Off
6. Remove jumper wire
7. Replace LED headers and Signal header
8. Power On

# Manaras Opera CDO Wiring

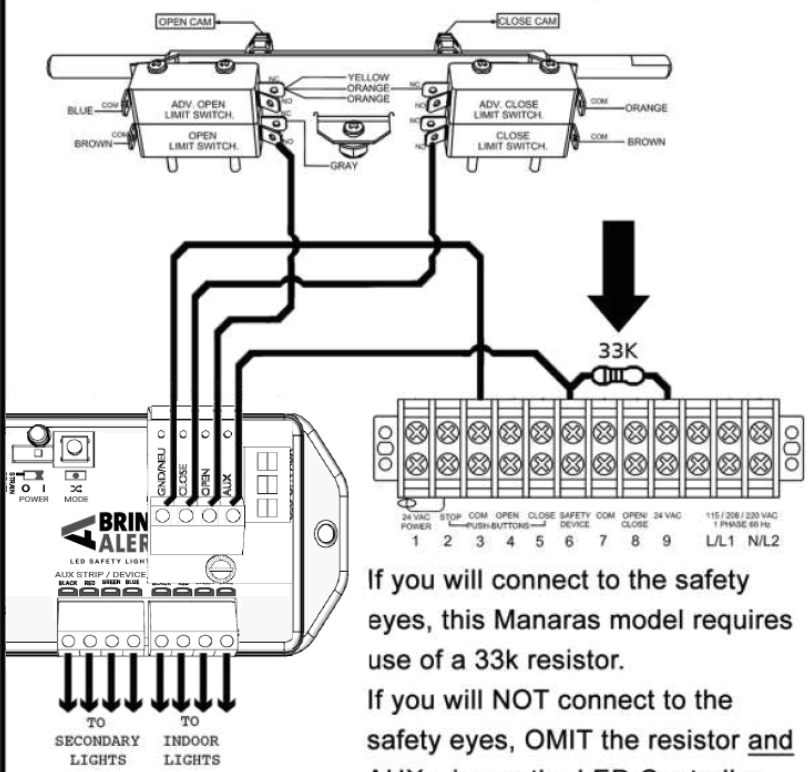

PROGRAM the LED CONTROLLER (use Mode 3):

1. Hold the Mode button for 3-4 seconds. Status LED will flash slowly.
2. Hold Mode button again for 3-4 seconds. Status LED will flash rapidly.

IF CONNECTING TO SAFETY EYES:

1. Power Off the LED Controller
2. Remove LED headers and Signal header
3. Attach jumper wire between Signal GND and Signal Aux.
4. Hold the Mode button and, while holding, set power switch to ON.
5. Let go of Mode button.
6. Power Off
7. Remove jumper wire
8. Replace LED headers and Signal header
9. Power On

If you will connect to the safety eyes, this Manaras model requires use of a 33k resistor.  
If you will NOT connect to the safety eyes, OMIT the resistor and AUX wire on the LED Controller.